



**BREAKERS & ATTACHMENTS**

**COMPACTOR MODEL**

**CMP 16 R - CMP 40 R**  
**CMP 70 R - CMP 120 R**



### **MTB COMPACTOR (CMP-R SERIES)**

CMP Hydraulic Compactors can be installed on carrier machines with hydraulic power units such as; mini excavators, backhoe loaders, excavators, etc. Hydraulic compactors carry out the compacting operation by applying high-frequency impact force. This vibration force can be used for compacting soil, granular materials, piles, driving posts and steel rods. The optional rotator system enables the compactor to rotate 360°.



# TECHNICAL INFORMATION

**CMP 16 R**

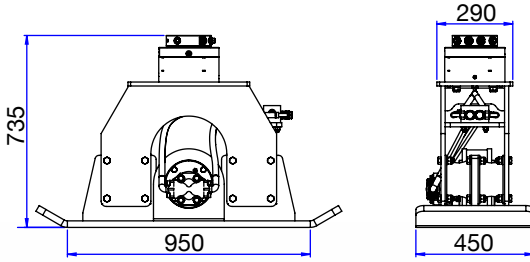

**CMP 40 R**

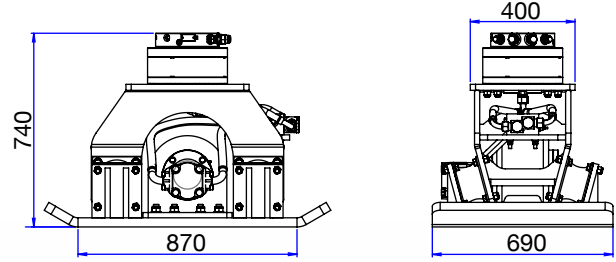

**CMP 70 R**

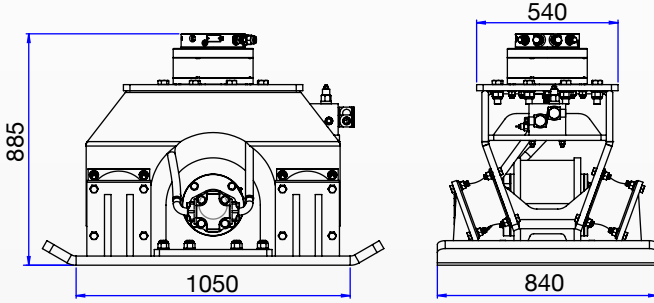

**CMP 120 R**

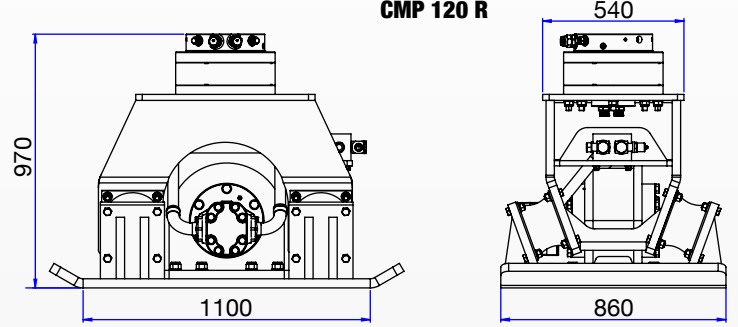

TECHNICAL INFORMATION	CMP 16 R	CMP 40 R	CMP 70 R	CMP 120 R
Working weight kg	295	611	971	1205
Power kg	1550	3000	6000	9900
Frequency N / min	2100	2000	2000	2100
Operating pressure (Hydromotor) bar	150	150	150	150
Max. Oil flow (Hydromotor) lpm	35	75	110	210
Operating pressure (Rotation) bar	250	250	250	250
Oil flow (Rotation) lpm	30-40	30-40	30-40	35-45
Height - C mm	735	740	885	970
Bottom plate - AxB mm	450x950	690x870	840x1050	860x1100
Carrier weight t	1,5-6	4-10	10-25	25-60

Rev. 27.11.24



**Factory**

Bahçelievler OSB Mh. 11. Cd. No: 4A  
59510 Kapaklı / Tekirdağ - TURKEY  
+90 282 768 25 00  
www.mtbbreakers.com - info@inanmakina.com



**WARNING!** The visuals and the information in this brochure are standard or optional depending on the version of the product.

İNAN MAKİNA A.Ş. saves the right to modify the values and designs shown in this brochure without notice.