



BREAKERS & ATTACHMENTS

BREAKER MODEL

38 IQ

ANTI BLANK-FIRING FEATURE

Piston and Cylinder Design

With our specially designed piston and cylinder, the breaker is prevented from blank-firing. This way, the tie-rods, bushings, retainers and the tools lifetime is prolonged. With this, the maintenance costs are lowered and the breaker is able to work for longer durations in tough excavation sites like stone quarries and marble quarries. The anti blank-firing feature guarantees that the operator will work safely and efficiently.

MORE DURABLE

Wearing Plates

Our breakers have longer lifetimes thanks to their highly resilient tall type wearing plates which were specially designed for the toughest operating conditions.

MORE RELIABLE

Minimum Vibration

Minimum vibration and maximum performance with our excellent impact absorbant vibration buffers and polyurethane-covered tie-rods.

Membrane and Accumulator

With its highly resilient accumulator and membrane, our breakers impact with the same energy on every single stroke, thus providing maximum efficiency even when working on the hardest materials.

Hydraulic Cushioning

In addition to the anti blank-firing feature, hydraulic cushioning protects the excavator by increasing the durability of the breaker.



TECHNICAL INFORMATION

38 IQ

Operating weight (a) kg	450
Oil Flow l/min	50~100
Impact Rate (b) bpm	490~990
Operating Pressure (c) bar	120~125
Input power (d) kW	10-20.8
Relief Pressure bar	180
Back Pressure Max. bar	10
Tool Diameter mm	80
Noise Level (e) LWA (dB)	127
Carrier Weight (f) t	6~9

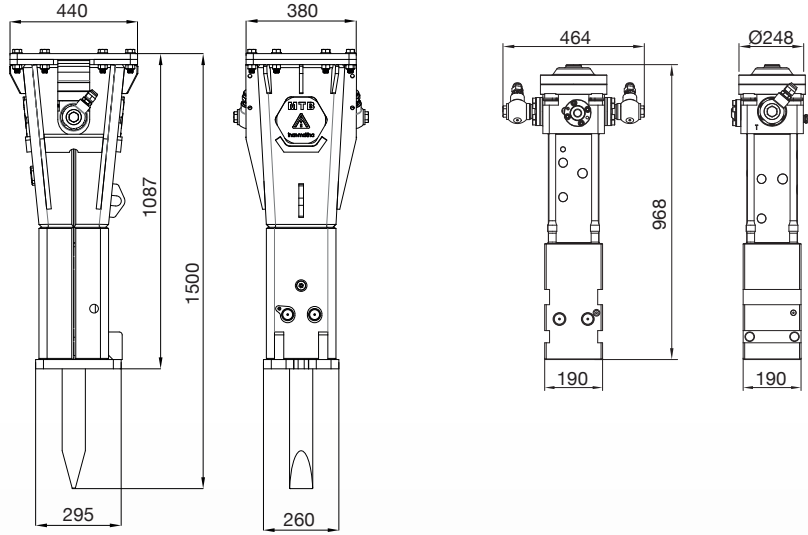

(a) It includes the approximate weight of the breaker, bracket, standard tool and hose weights.

(b) Actual impact frequency depends on the oil flow, oil viscosity, temperature and the material to be broken.

(c) Actual pressure depends on the oil flow, oil viscosity, temperature, material to be broken and the return pressure.

(d) Input power directly effects fuel consumption. Low input power (kW) requirement means low fuel consumption.

(e) Guaranteed sound power testing results according to directive 2000/14/EC (Guaranteed dB(A)=Measured Value +3 dB).

(f) If the carrier machine is out of the optimum range, ask the carrier machine manufacturer for allowed attachment weight.

TOOL PROPERTIES

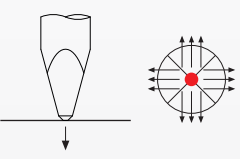
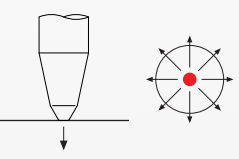
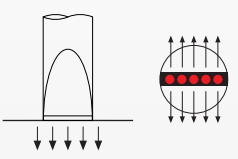
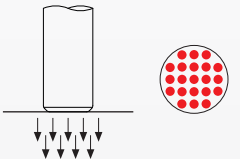
	Pyramid	Moil	Chisel	Blunt
Operating Principle				
Key Properties	<ul style="list-style-type: none"> Breaking in four directions General demolition 	<ul style="list-style-type: none"> Breaking in all directions Suitable for general use 	<ul style="list-style-type: none"> Breaking in two directions Suitable for general purpose by demolition 	<ul style="list-style-type: none"> Good energy transfer Demolition – Impact breaking

SPECIAL TOOLS

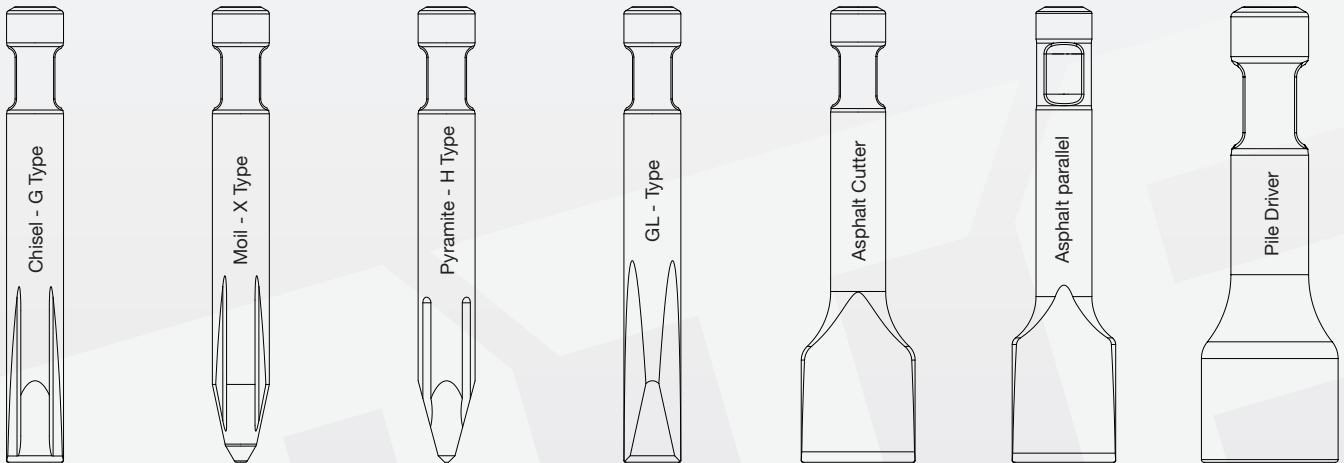

Rev. 150824



Factory

Bahçelievler OSB Mh. 11. Cd. No: 4A

59510 Kapaklı / Tekirdağ - TURKEY

+90 282 768 25 00

www.mtbbreakers.com - info@inanmakina.com



WARNING! The visuals and the information in this brochure are standard or optional depending on the version of the product.

İNAN MAKİNA A.Ş. saves the right to modify the values and designs shown in this brochure without notice.