



BREAKERS & ATTACHMENTS

BREAKER MODEL

175 IQ

ANTI BLANK-FIRING FEATURE

Piston and Cylinder Design

With our specially designed piston and cylinder, the breaker is prevented from blank-firing. This way, the tie-rods, bushings, retainers and the tools lifetime is prolonged. With this, the maintenance costs are lowered and the breaker is able to work for longer durations in tough excavation sites like stone quarries and marble quarries. The anti blank-firing feature guarantees that the operator will work safely and efficiently.

MORE DURABLE

A-Type Housings

A-type housings are produced with highly wearing-resistant plates and were designed with consideration for different working environments. They are suitable for all of your needs in difficult excavating operations with their durable housings.

C-Type Chassis (Optional)

Thanks to our C-Type chassis covered with wearing-resistant plates, maximum durability is provided even in the toughest conditions

Wearing Plates

Our breakers have longer lifetimes thanks to their highly resilient tall type wearing plates which were specially designed for the toughest operating conditions.

Dual Retainers

Dual retainer design makes sure that the tool impacts with more balance.

MORE RELIABLE

Minimum Vibration

Minimum vibration and maximum performance with our excellent impact absorbant vibration buffers and polyurethane-covered tie-rods.

Membrane and Accumulator

With its highly resilient accumulator and membrane, our breakers impact with the same energy on every single stroke, thus providing maximum efficiency even when working on the hardest materials.

Hydraulic Cushioning

In addition to the anti blank-firing feature, hydraulic cushioning protects the excavator by increasing the durability of the breaker.



inan makina
SANAYİ VE TİCARET A.Ş.



TECHNICAL INFORMATION

175 IQ

Operating weight (a) kg	1950
Oil Flow l/min	120~180
Impact Rate (b) bpm	360~550
Operating Pressure (c) bar	135~140
Input power (d) kW	27~42
Relief Pressure bar	200
Back Pressure Max. bar	8
Tool Diameter mm	135
Noise Level (e) LWA (dB)	129
Carrier Weight (f) t	22~29

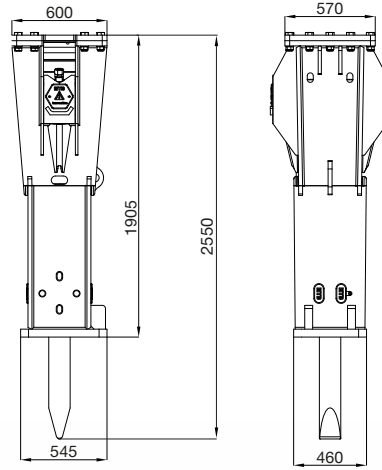

- (a) Approximately includes breaker, bracket, standard tip and hose weights; total weight may vary depending on the brand and model of the work machines.
 (b) Actual impact frequency depends on the oil flow, oil viscosity, temperature and the material to be broken.
 (c) Actual pressure depends on the oil flow, oil viscosity, temperature, material to be broken and the return pressure.
 (d) Input power directly effects fuel consumption. Low input power (kW) requirement means low fuel consumption.
 (e) Guaranteed sound power testing results according to directive 2000/14/EC (Guaranteed dB(A)–Measured Value +3 dB).
 (f) If the carrier machine is out of the optimum range, ask the carrier machine manufacturer for allowed attachment weight.

TOOL PROPERTIES

	Pyramid	Moil	Chisel	Blunt
Operating Principle				
Key Properties	Breaking in four directions General demolition	Breaking in all directions Suitable for general use	Breaking in two directions Suitable for general purpose by demolition	Good energy transfer Demolition – Impact breaking

SPECIAL TOOLS

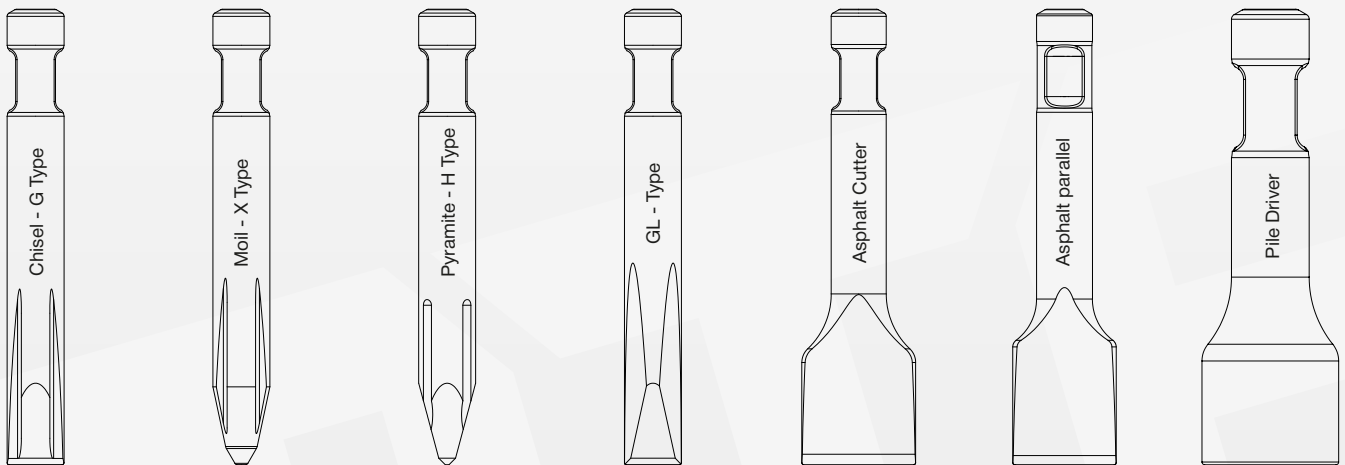

Rev. 280825



Factory

Bahçelievler OSB Mh. 11. Cd. No: 4A
 59510 Kapaklı / Tekirdağ - TURKEY
 +90 282 768 25 00

www.mtbbreakers.com - info@inanmakina.com



WARNING! The visuals and the information in this brochure are standard or optional depending on the version of the product.

İNAN MAKİNA A.Ş. saves the right to modify the values and designs shown in this brochure without notice.